

# CRATING

UOVO's professional technical team has decades of experience developing crating solutions for artworks of all types. We offer a variety of core crating options with endless customizations to meet your needs.



Our dedicated Account Managers and expert craters will manage your entire project from start to finish, including local transportation, international shipping, installation, and storage. Please consult your Account Manager to determine the crate style best suited for your artwork.

## FEATURED CRATING SOLUTIONS

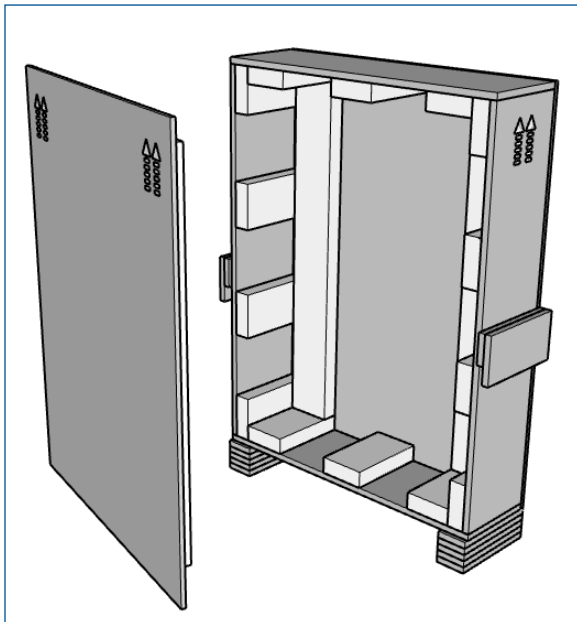

### LOW PROFILE CRATE

An economical solution for most flat works and objects. Low-Profile Crates do not feature any exterior reinforcing or battening. They are suitable for storage, domestic transit, and one-way international shipments.

#### Key features include:

- Plywood walls, front and back.
- Standard height skid.
- 2" ethafoam cushion around the object.
- Screw closures.

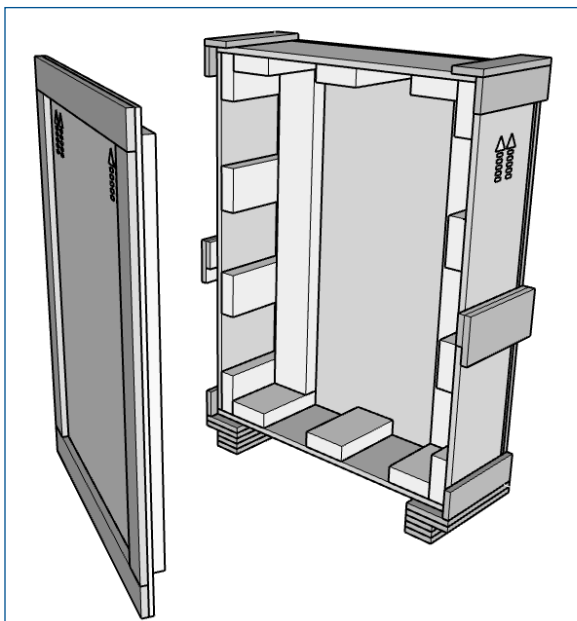

### STANDARD CRATE

This crate provides enhanced strength and durability with battened exteriors to protect art and fragile objects. Standard Crates are designed to withstand multiple uses and can be outfitted to accommodate a variety of different mediums. They are ideal for both international and domestic travel.

#### Key features include:

- Plywood walls, front and back, reinforced with battens.
- Standard height skid.
- 2" ethafoam cushion around the object.
- Screw closures.



## TAILORED CRATING SOLUTIONS FOR EVERY ARTWORK

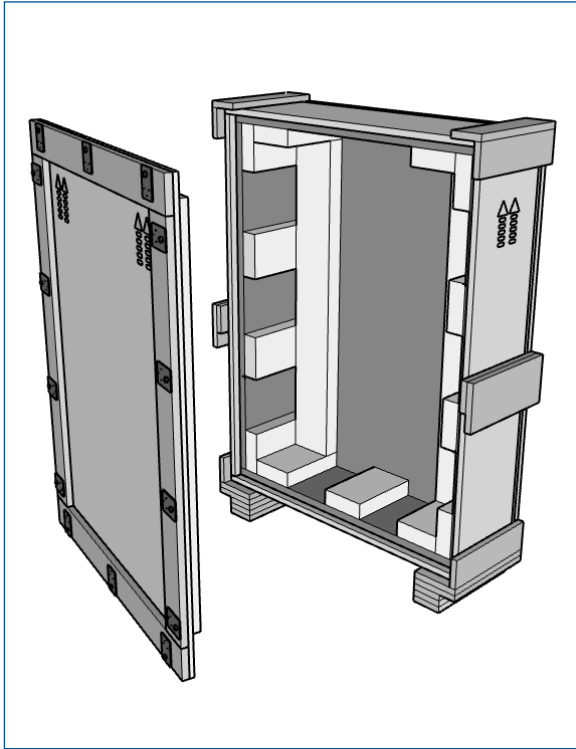

### EXHIBITION CRATE

The highest standard for fine art museums and institutions, Exhibition Crates are custom-built for objects that will travel extensively, making them ideal for international and domestic air freight. Exhibition Crates function as insulated micro-environments, reducing fluctuations in temperature and impact shocks that may be encountered during travel.

#### Key features include:

- Plywood walls, front and back, reinforced with battens.
- Standard height skid.
- 2" ethafoam cushion around the object.
- 1.5"-2" insulation on all sides.
- Bolt closures as standard; other hardware available upon request (e.g., butterfly closures, screws).
- Enhanced weather resistance: seams sealed with silicone, gasket-sealed lid, and optional plywood rain-cap that spans over the top.
- All exterior edges are routed/rounded over.
- Polyurethane finish on the exterior as standard or paint upon request

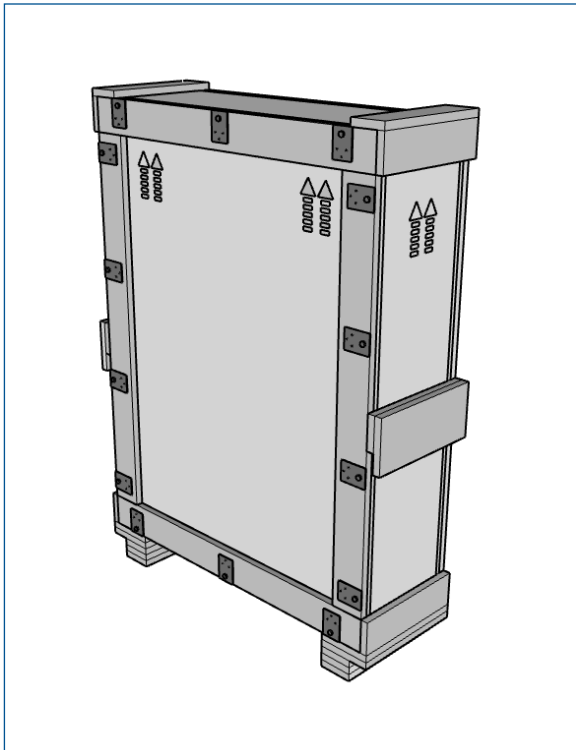

## CUSTOMIZATIONS AND ACCESSORIES

In addition to our featured crating solutions, we offer many types of crating configurations and accessories. For paintings and sculptures requiring specialized protection, we recommend travel frames and slat crates. These crates can serve as the primary container for storage and domestic transit or be used as internal packing within a larger crate. This method enhances shock absorption and provides added protection for artworks during transport.

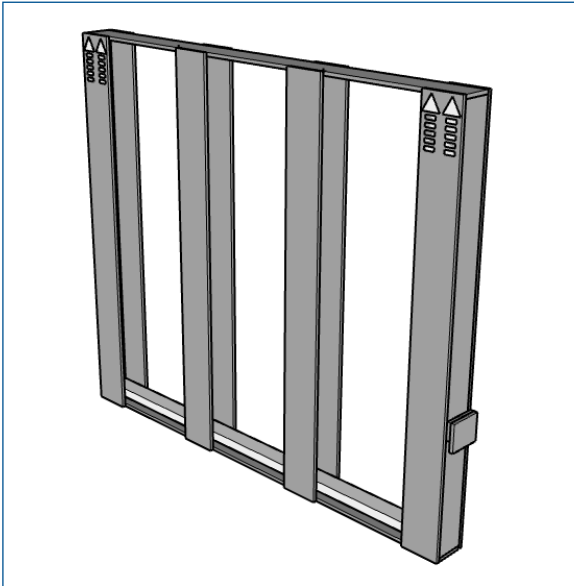

### OPEN TRAVEL FRAME

An economical solution, this travel frame is ideal for storage and local transit, offering secure protection for paintings without direct surface contact.

#### Key features include:

- Slat construction for walls, front, and back.
- 3" of space around the artwork to accommodate Oz clips.
- Optional safety block with foam and Volara along the riding edge.
- Poly-wrapped for additional protection.

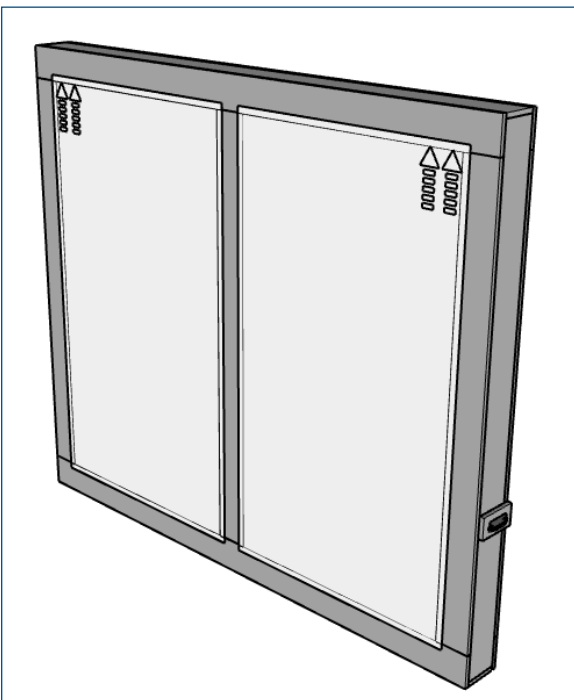

### CLOSED TRAVEL FRAME

Designed to provide the highest level of protection for canvases, this frame is ideal for storage and domestic transit via art shuttle. With Coroplast facings on both sides, it provides added protection during transport.

The front is a single assembly - it can be removed as a single unit. This makes it quicker and easier to open and close compared to designs with individual removable slats, saving time and simplifying handling.

#### Key features include:

- 3" of space around the artwork to accommodate Oz clips.
- Front and back are covered in Coroplast.
- Optional safety block with foam and Volara along the riding edge.
- All exterior edges are routed and rounded.



## CUSTOMIZATIONS AND ACCESSORIES

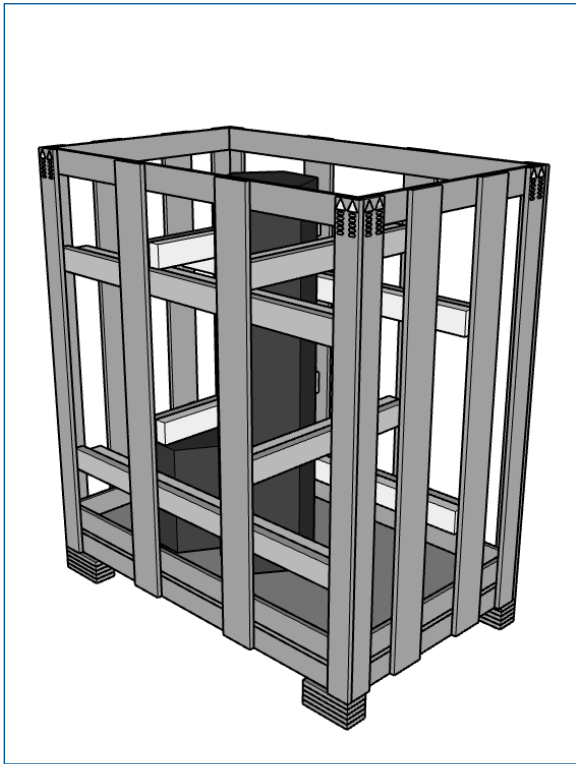

### SLAT CRATE

The perfect packing solution for sculptures requiring specialized access for secure bracing.

It is ideal for storage, domestic ground transit, and can be placed inside an external crate for added protection and airfreight.

#### Key features include:

- Slats assembled to create lattice walls.
- All walls are removable.
- Pallet bottom or skids, depending on the object.
- Often poly-wrapped for additional protection.

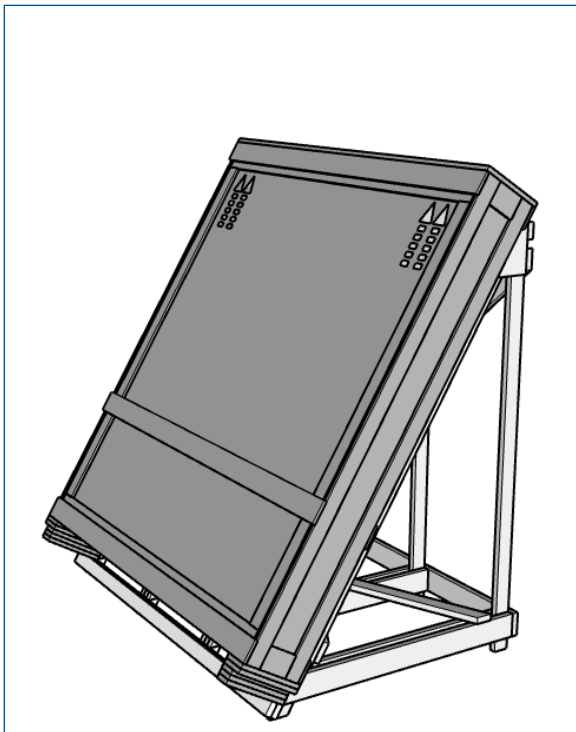

### A-FRAME

The ideal solution for fine art shuttles and air travel for oversized 2-D artwork. This frame is designed to easily navigate large crates through doorway restrictions.

#### Key features include:

- Truss-style assembly supports both crates and travel frames.
- Compatible with pallet jacks from the narrow side for easy handling.



# Crate Offerings

Each crate is meticulously designed with the safety of the artwork as the top priority. Based on the specific needs of each piece, we offer custom-built options, including Front Load, Top Load, Front and Top Load, End Load, or All Sides Removable crates.

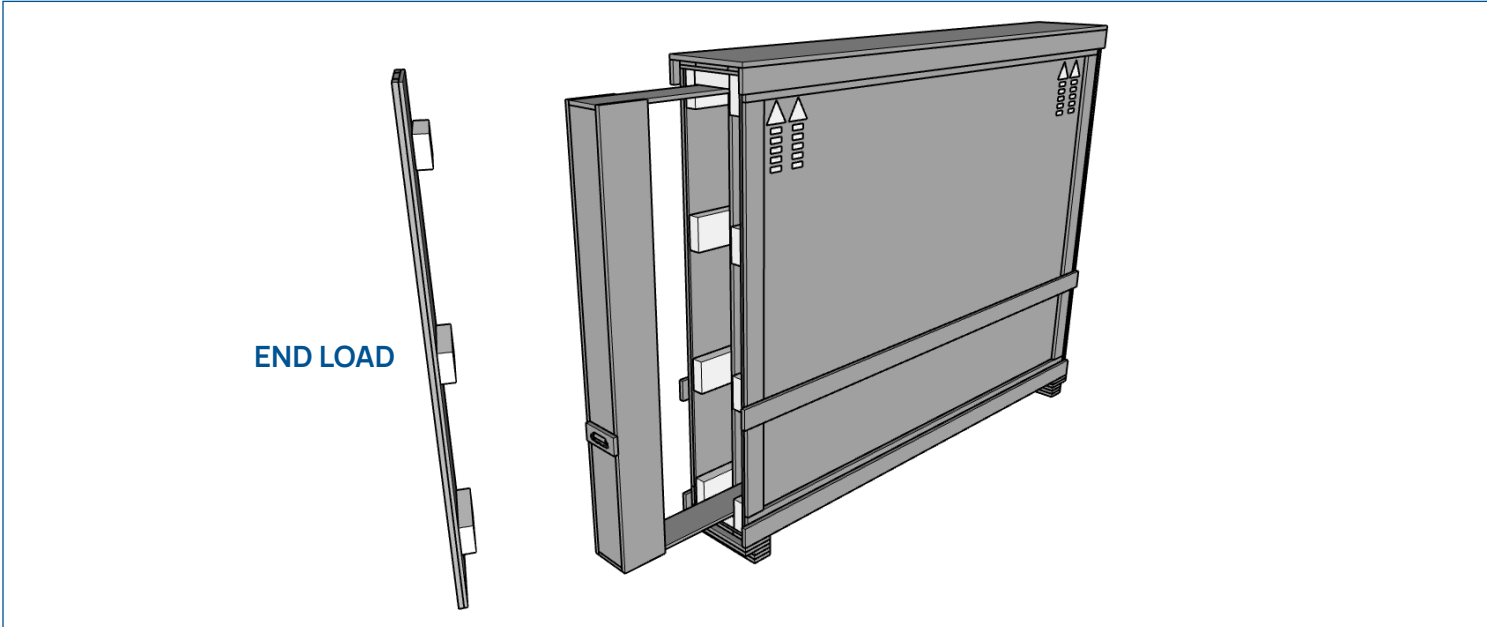
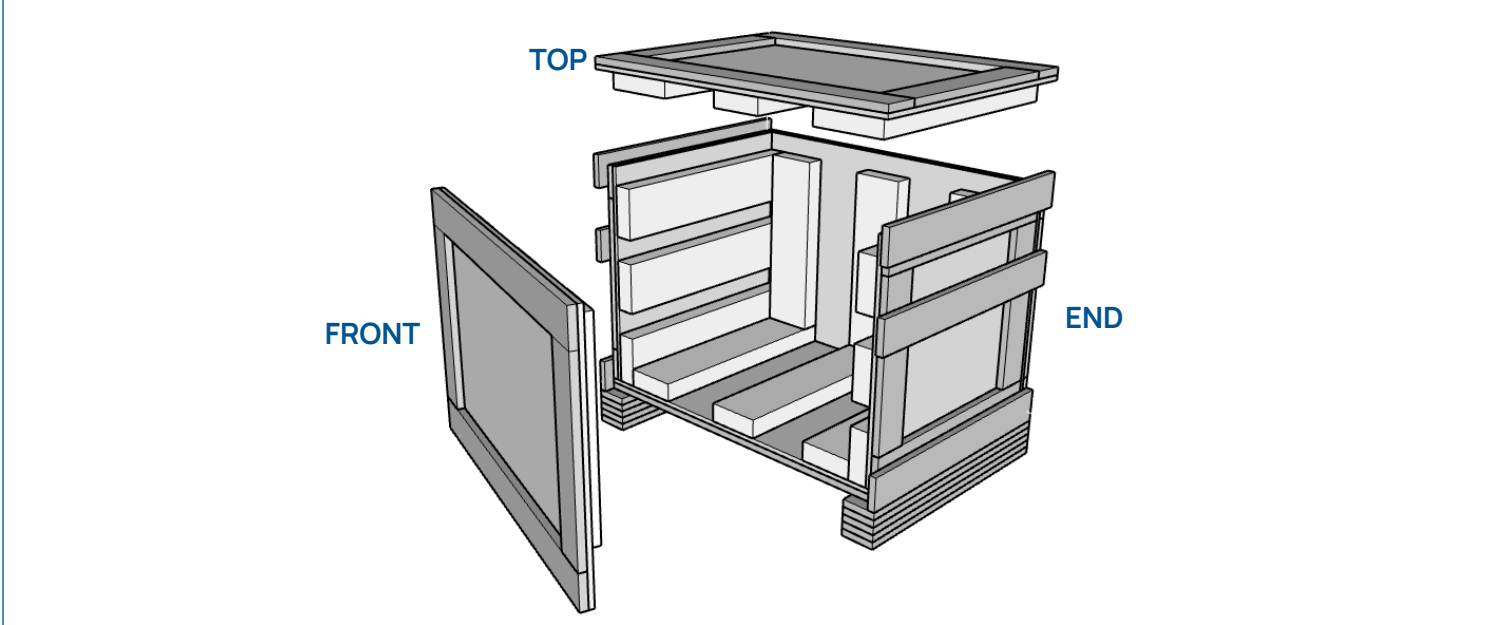

Contact us to learn more today.

833-344-8686

info@uovo.com

www.uovo.com

Facebook Instagram LinkedIn @uovo.art

